

Tyre diameter
750 - 1.600 mm
30 - 63"

Lift capacity
1.500 kg
3.300 lbs

Ideal for:
Tyre Manufacturers
Tyre Retreaders
Tyre Distributors / Dealers
Casing Dealers
OEM / Truck Manufacturers

Easy
Stacker
1600

Save
time
Improve
safety



Professional tools for handling small OTR and AGRO tyres

- Stacking, loading, unloading and internal logistic
- Reduce working hours at loading/unloading
- Eliminate physical and stressful work – improve safety
- Optimize warehouse and logistic without need for pallets
- Easy hook on/off attachment
- Customization available

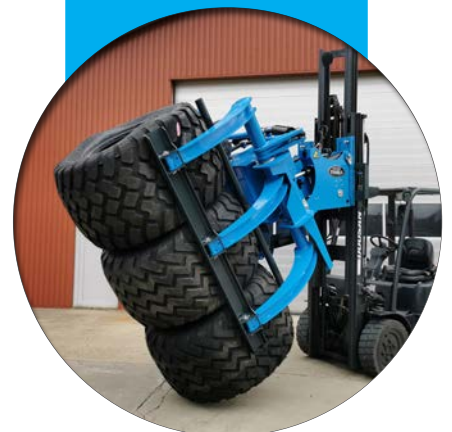

Experts in Tyre Handling Equipment



Easy Stacker 1600

The Easy Stacker 1600 is designed to handle stacks of small OTR and AGRO tyres, military, industrial and commercial truck tyres, with a firm grip and with movements optimized to operate in tight space in warehouses, production areas and in trucks, trailers and containers. The Easy Stacker 1600 takes over most manual processes of lifting and moving large tyres – reducing strain and risks for the operator significantly.

Capability

With a gripping range of Ø750-1.600 mm (30-63”), a grip length of 2.100 mm (82”) and a lifting capacity of 1.500 kg (3.300 lbs) the Easy Stacker 1600 can handle stacks of medium size tyres. With the 90° tilt module rows of tyres can be stacked and makes loading, unloading and internal transportation easy, fast, and safe.



Tyre Manufacturers

Where the logistic is not fully automated, the Easy Stacker can be a very useful and effective tool to use in production areas, warehouses and shipping departments.

Tyre Retreaders

Stacking, loading, unloading, internal logistic and effective use of storing facilities. Compared to manual handling, the Stacker can here make very profitable improvements and lift your handling procedures to a higher level.



Tyre Distributors / Dealers

Loading and unloading trailers and containers. Effective stacking and optimize use of warehouse and other storage facilities with or without pallets. Internal transportation with a safe grip.



OEM / Truck Manufacturers

Unloading tyres. Place and organize the tyres effectively in stock with or without pallets. Move tyre to assembly lines with a safe grip.



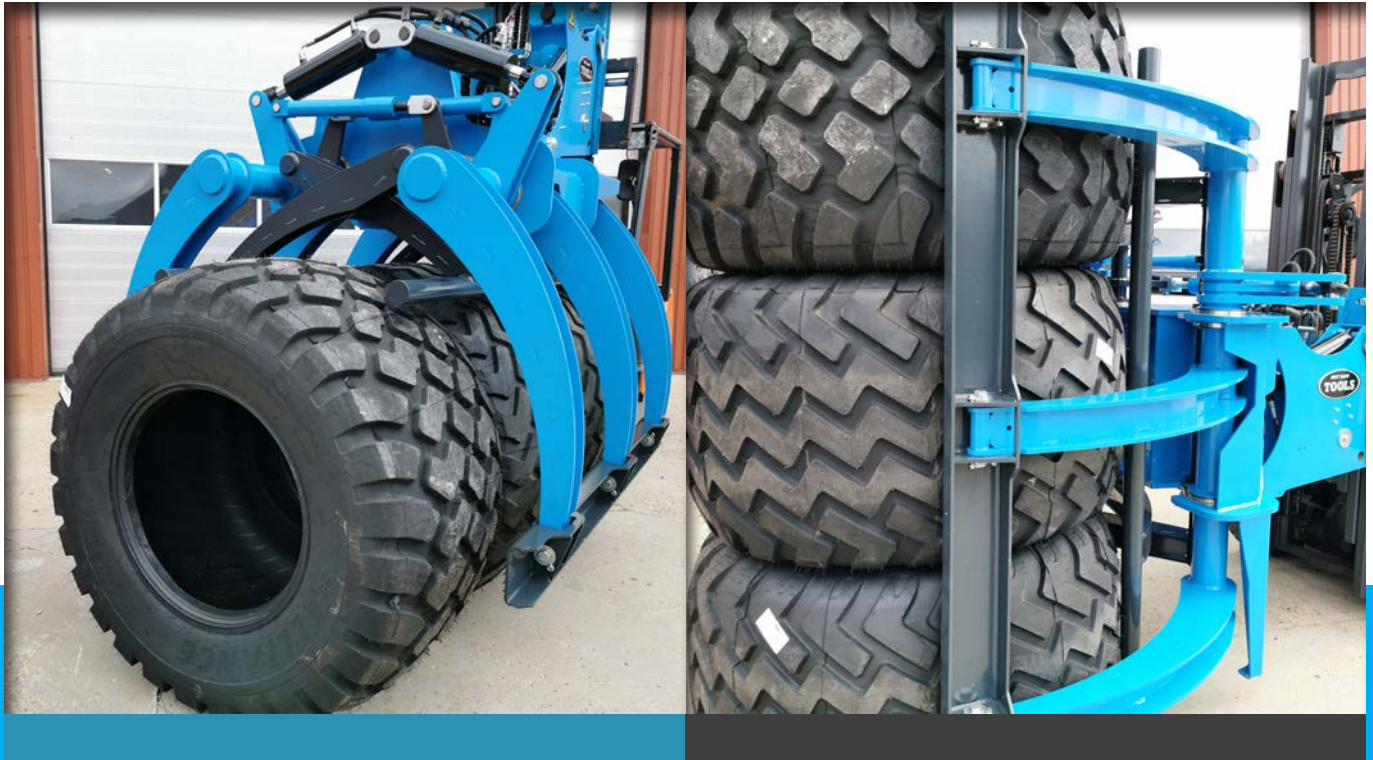

Standard features

90° tilt, horizontal to vertical

Stacking of tyres

Grip a line of small OTR and AGRO tyres on the floor, and tilt them up to vertical position.

Place stacks on stacks to use the height of the warehouse and double the capacity without any shelf system and without any need for pallets.

Can grip piles of tyres with limited space around the pile

In order to use the space effectively and to operate in trucks, trailers and containers.

Loading and unloading of trailers etc.

Can be performed from just one side with the reach of the Stacker.

Can be performed by just one man without any physical and stressful work.

Required accessory

Quick Shift Module

The Quick Shift Module is a standard and integrated part of the Easy Stacker. It is mounted on the forklift, and the Easy Stacker is then hooked on to this module. By using the Quick Shift Module, the Stacker can easily be hooked on and off.

Optional accessories

Fork Module

The Fork Module is designed to be hooked on to the Quick Shift Module, and makes quick shift between Stacker and forks easy.

Hydraulic Quick Shift

The quick shift can be speeded up to less than half a minute by using a hydraulic multi connection. Instead of changing two hydraulic hoses by screw couplings, the hydraulic can be changed by one handle in few seconds.

Gripping surfaces

The gripping surfaces are conically mounted to handle fully inflated wheels. Standard surface is a steel mesh. Other gripping surfaces are available.

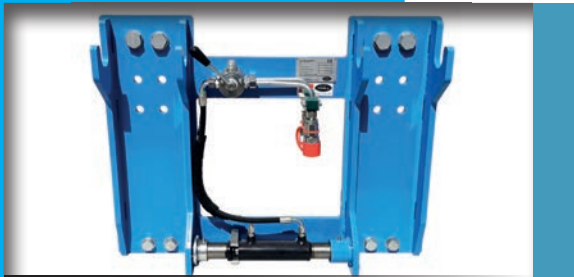

Quick Shift Module - screw coupling

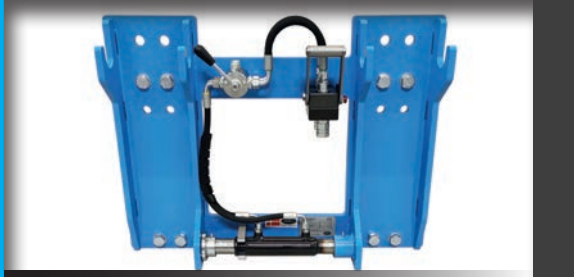

Quick Shift Module - hydraulic multi connection

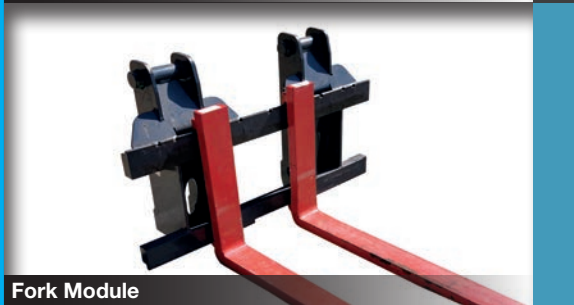

Fork Module

Technical Specifications

Lifting capacity:	1.500 kg (3.300 lbs)
Tyre diameter:	750 - 1.600 mm (30 - 63")
Grip length:	2.100 mm (82")
Electrical supply:	12/24 V / min 10A
Hydraulic:	1 double acting hydraulic valve
Pressure min-max:	150 - 250 bar (2.175 - 3.626 psi)
Return pressure:	max. 10 bar (145 psi)
Flow:	max. 50 l/min. (13 gal/min.)
Lifting height:	Forklift specific
Tilt, horizontal to vertical:	90°
Net weight:	1.210 kg (2.662 lbs)
Attachment:	ISO/FEM/ITA Class 3 or 4

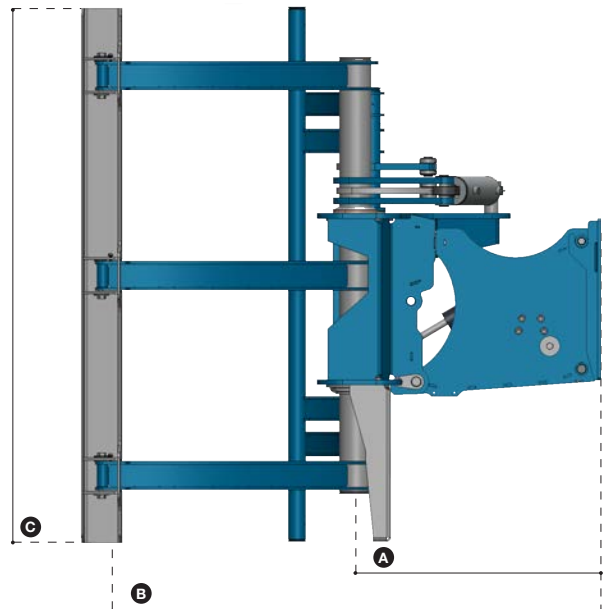

A CoG Machine = 960 mm (38")

B CoG Load = 1.900 mm (75")

C Height = 2.100 mm (83")

Authorized Dealer



+45 72 344 344
 info@justeasytools.dk
 www.justeasytools.com
 VAT no.: DK33644809

Just Easy Tools ApS
 Nupark 51
 DK-7500 Holstebro
 Denmark