

Ideal for:  
Tyre Manufacturers  
Tyre Retreaders  
Tyre Distributors / Dealers  
Casing Dealers  
OEM / Truck Manufacturers

# Easy Stacker 1200

Save  
time  
Improve  
safety



## Professional tools for handling truck tyres

- Stacking, loading, unloading and internal logistic
- Reduce working hours of manual loading/unloading up to 90%
- Eliminate physical and stressful work – improve safety
- Optimize warehouse and logistic without need for pallets
- Easy hook on/off attachment
- Customization available



Experts in Tyre Handling Equipment



# Developed for optimal handling of truck tyres

The Easy Stacker 1200 is designed to stack and to handle stacks of truck tyres with a firm grip and with movements optimized to operate in tight space in warehouses, production areas, trucks and containers.

## Capability

With a gripping range of Ø550 - 1.200 mm (22 - 47") a grip length of 2.100 mm (82") and a lifting capacity of 750 kg (1.650 lbs) the Easy Stacker 1200 can handle stacks of almost any truck tyre. With the 90° tilt module rows of tyres can be stacked, and the design enables loading and unloading of containers and of trailers. Without any stressful and physical work.



## Tyre Manufacturers

Where the logistic is not fully automated, the Easy Stacker can be a very useful and effective tool to use in production areas, warehouses and shipping departments.

## Tyre Retreaders

Stacking, loading, unloading, internal logistic and effective use of storing facilities. Compared to manual handling, the Stacker can here make very profitable improvements and lift your handling procedures to a higher level.



## Tyre Distributors / Dealers

Loading and unloading trailers and containers. Effective stacking and optimize use of warehouse and other storage facilities with or without pallets. Internal transportation with a safe grip of the tyres.



## OEM / Truck Manufacturers

Unloading truck tyres. Place and organize effectively in stock with or without pallets. Move to assembly lines with a safe grip.



# Estimated Working Hours

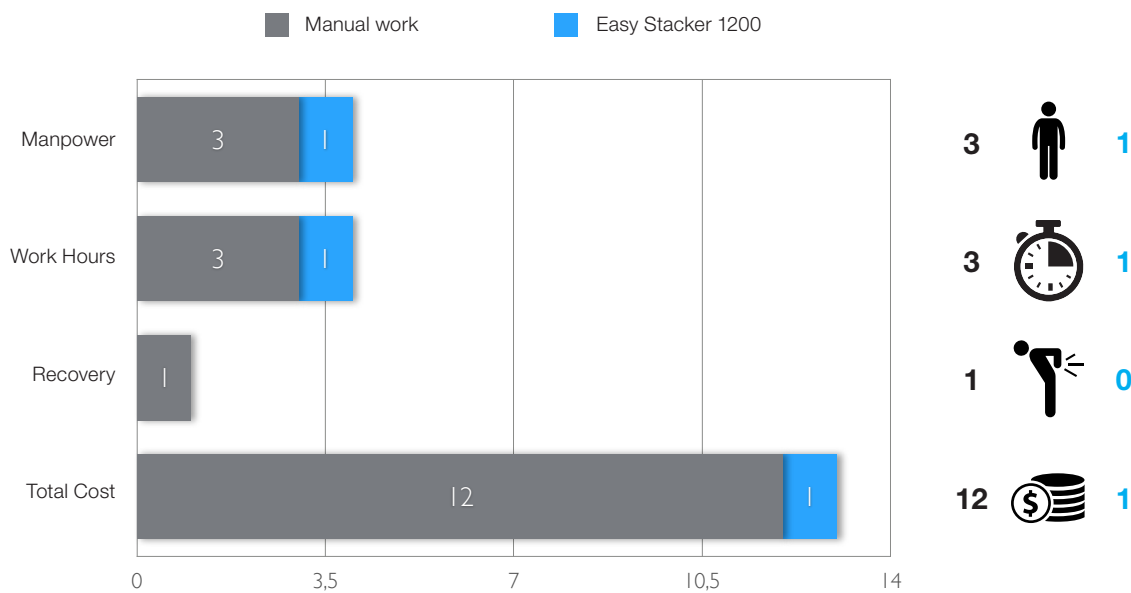

The potential of an Easy Stacker 1200 investment is extensive. Savings of over 90% of current working hours can be achieved. The above example is based on a case, where a fully loaded truck is unloaded for tyres manually.

## Standard features

**90° tilt, horizontal to vertical**

### Stacking of truck tyres

Roll/place a line of 6-8 truck tyres on the floor. Grip and tilt them up to vertical position.

Place stacks on stacks to use the height of the warehouse and double the capacity without any shelf system and without any need for pallets.

### Can grip piles of tyres without space around it.

In order to use the space effectively and to operate in trucks, trailers and containers.

### Loading and unloading of trailers etc.

Can be performed from just one side with the reach of the Stacker.

Can be performed by just one man and in less than one hour. Maybe even including transport to or from the stock.

And without any physical and stressful work.

## Required accessory

### Quick Shift Module

The Quick Shift Module is a standard and integrated part of the Easy Stacker. It is mounted on the forklift, and the Easy Stacker is then hooked on to this module. By using the Quick Shift Module, the Stacker can easily be hooked on and off.

## Optional accessories

### Fork Module

The Fork Module is designed to be hooked on to the Quick Shift Module, and makes quick shift between Stacker and forks easy.

### Hydraulic Quick Shift

The quick shift can be speeded up to less than half a minute by using a hydraulic multi connection. Instead of changing two hydraulic hoses by screw couplings, the hydraulic can be changed by one handle in few seconds.

### Handle weared and inflated tyres

Wedges can be built-in behind the lower end of the stone coated grip to ensure a firm grip of the bottom tyres.

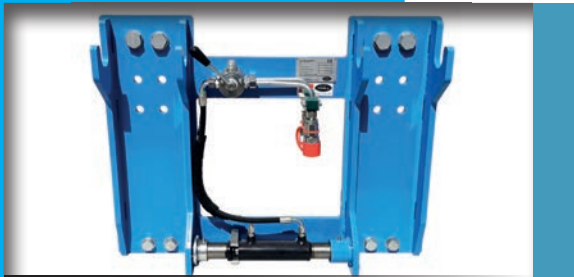

Quick Shift Module - screw coupling

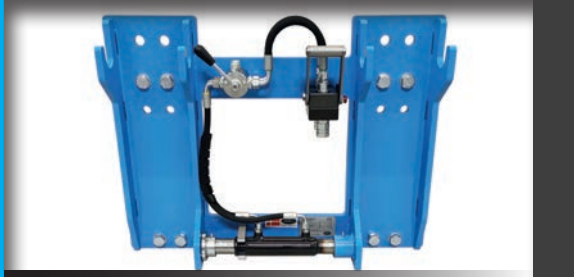

Quick Shift Module - hydraulic multi connection

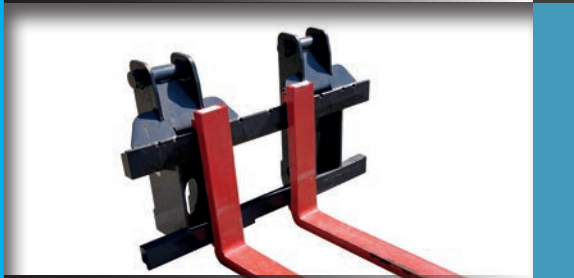

Fork Module



Handle worn and inflated tyres

### Technical Specifications

|                              |                                   |
|------------------------------|-----------------------------------|
| Lifting capacity:            | 750 kg (1.650 lbs)                |
| Tyre diameter:               | 550 - 1.200 mm (22 - 47")         |
| Grip length:                 | 2.100 mm (82")                    |
| Electrical supply:           | 12/24 V / min 10A                 |
| Hydraulic:                   | 1 double acting hydraulic valve   |
| Pressure min-max:            | 150 - 250 bar (2.175 - 3.626 psi) |
| Return pressure:             | max. 10 bar (145 psi)             |
| Flow:                        | max. 50 l/min. (13 gal/min.)      |
| Lifting height:              | Forklift specific                 |
| Tilt horizontal to vertical: | 90°                               |
| Net weight:                  | 630 kg (1.386 lbs)                |
| Attachment:                  | ISO/FEM/ITA Class 2 or 3          |

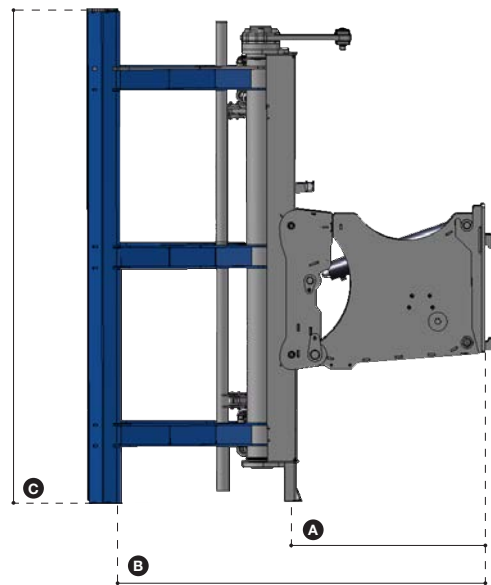

- A** CoG Machine = 825 mm (33")
- B** CoG Load = 1.580 mm (62")
- C** Height = 2.100 mm (83")

Authorized Dealer



+45 72 344 344  
 info@justeasytools.dk  
 www.justeasytools.com  
 VAT no.: DK33644809

Just Easy Tools ApS  
 Nupark 51  
 DK-7500 Holstebro  
 Denmark