

Ideal for:
Farmers / AGRO Workshops / OEM
Tyre Manufacturers / Retreaders
Tyre Distributors / Dealers
Tyre Service
Ports

Easy
Gripper
2160
Compact

Tyre
diameter
700 - 2.160 mm
28 - 85"

Lift
capacity
1.000 kg
2.200 lbs

Save
time
Improve
safety

Professional tools for handling of AGRO tyres and small OTR

- Unique 3-point grip
- Precise rotation +/-25°
- Horizontal to vertical tilt depending on carrier
- Integrated camera system for optimal view
- Prevent damage to tyres, rims & equipment
- Tools for safe handling of tyre rings
- Easy hook on/off attachment



Experts in Tyre Handling Equipment



Easy Gripper

The Easy Gripper product range is designed to help professional tyre technicians in a multitude of conditions and situations. Implementing The Easy Gripper makes tyre handling faster and safer, while preventing damages to tyres, rims and equipment.

Capability

With a gripping range of Ø700 - 2.160 mm (28 - 85") and a lifting capacity of 1 ton (2.200 lbs) at a CoG of 500 mm (20") from face of gripper, the Easy Gripper 2160 Compact is developed to handle AGRO and light OTR tyres. On request the gripping diameter can be extended to Ø2.400 mm (94") to handle even the biggest AGRO tyres.



Manufacturers / dealers

Optimized tyre logistics - stack and store tyres and wheels both horizontally and vertically at workshops and warehouse areas. Fast and safe loading and unloading.

Agriculture

Safe and efficient mount and demount of large AGRO tyres with no damages of rims and equipment. Minimize tyre wear and optimize ground pressure, helping protect crops.



Ports

Reduces the down time and improves the safety for the tyre technicians while handling tyres and wheels on Straddle Carriers, Reach Stackers, AGVs and RTG cranes.

Breakdown service

Mounted on front loaders, telehandlers or truck cranes you get a perfect and safe solution to provide tyre service in any environment with just one or two operators ... faster than usually.

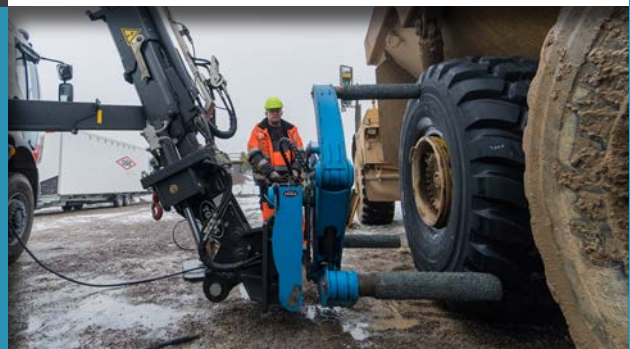

Electrical stackers and reach trucks



On electrical stackers and reach trucks and when working space is limited, see Easy Gripper Workshop.

Front loaders and telehandlers



The Easy Gripper 2160 Compact is a good choice depending on the tilt provided by the carrier.

Truck cranes



By use of our Crane Module the Easy Gripper 2160 Compact also fit with almost any truck crane system.



Standard Features

Unique and safe 3-point grip

Prevents accidents.
Prevents deformation of tyres.
Prevents damages to tyres, rims and equipment.

Integrated camera system for optimal view

With automatic IR function in insufficient lighting conditions.

Precise rotation +/-25°

Horizontal to vertical tilt depending on carrier

Compact attachment system

Can be customized with quick shift option depending on carrier.



Integrated camera system for optimal view



Unique and safe 3-point grip

Optional accessories

Easy shift of gripping pipes for various purposes

Telescopic pipes for long reach, to provide room for the tyre technicians and for dual tyre handling.
Flat top arm for limited tyre clearance.

Tools for safe handling of tyre rings

Special designed Ring Handling Tools for handling multi-piece rim wheels. With the Ring Handling Tools the tyre technicians can grip, hold, press, or place tyres, rims and rings as needed
- a major improvement of safety and efficiency!



Tools for safe handling of tyre rings

Customization on request



Customized attachment system



Telescopic pipes for long reach



Flat top arm for limited tyre clearance

Technical Specifications

Weight:	470 kg (1.034 lbs)
Lifting capacity:	1.000 kg (2.200 lbs) at C from B 500 mm (19.7")
	645 kg (1.422 lbs) at D from B 775 mm (30.5")
Tyre diameter:	700 - 2.160 mm (27.6 - 85.0")
Standard pipes:	Ø89 x 600 mm (3.5 x 23.6")
Telescopic pipes:	Ø100 x 600 -> 875 mm (3.9 x 23.6 -> 34.5")
Attachment:	ISO/FEM/ITA Class 2 or 3 / Loader specific

- A** CoG Gripper = 370 mm (14.6")
- B** Face of Gripper = 425 mm (16.7")
- C** CoG Load1 = 925 mm (36.4")
- D** CoG Load2 = 1.200 mm (47.2")

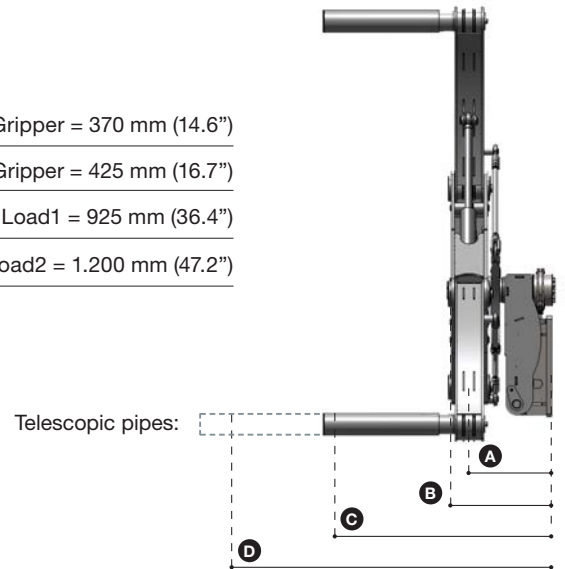

Technical Requirements

Lifting capacity:	Individual calculation
Electrical supply:	12/24 V / min 10A
Hydraulic:	1 double acting hydraulic valve
Pressure min-max:	150 - 250 bar (2.175 - 3.626 psi)
Return pressure:	max. 10 bar (145 psi)
Flow:	max. 50 l/min. (13 gal/min.)

Authorized Dealer



+45 72 344 344
 info@justeasytools.dk
 www.justeasytools.com
 VAT no.: DK33644809

Just Easy Tools ApS
 Nupark 51
 DK-7500 Holstebro
 Denmark